

Crane lifting eye optional  
Article number: 910020255

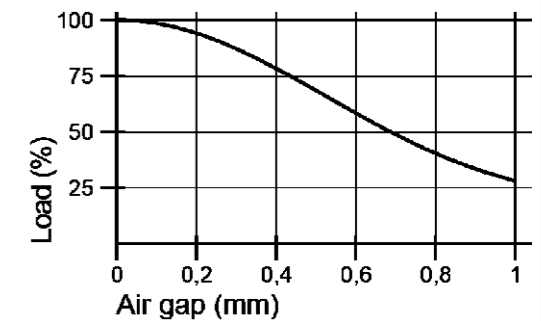
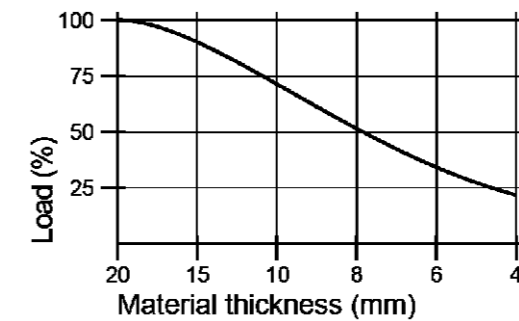
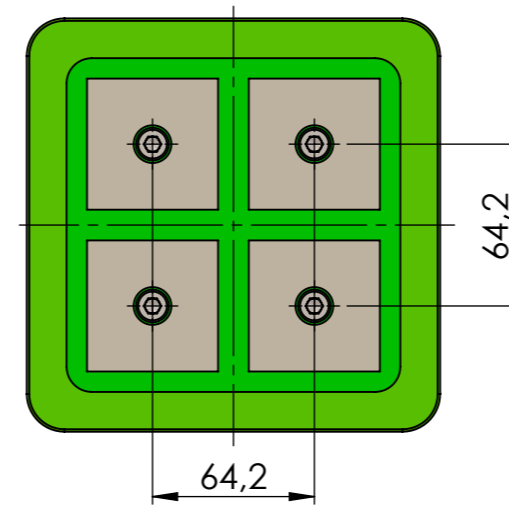
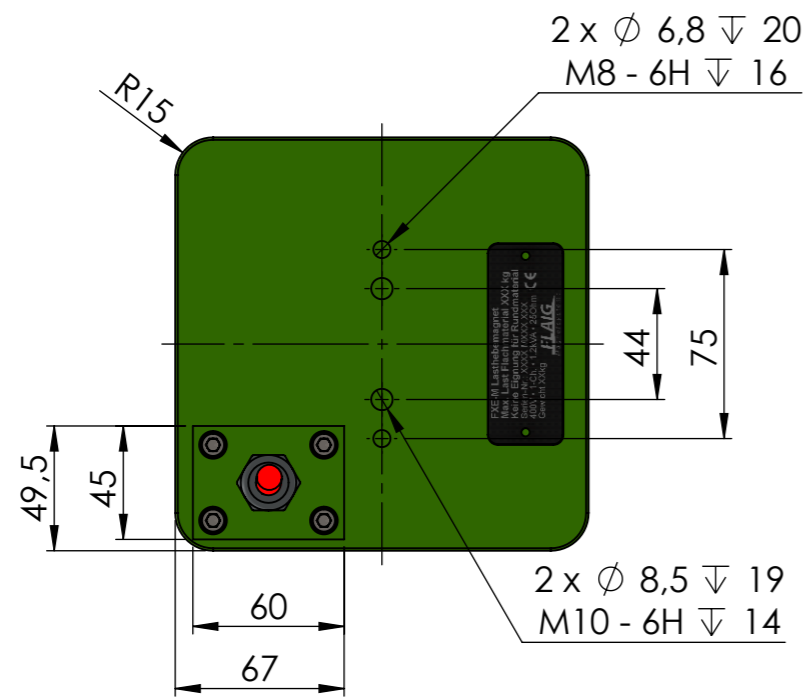
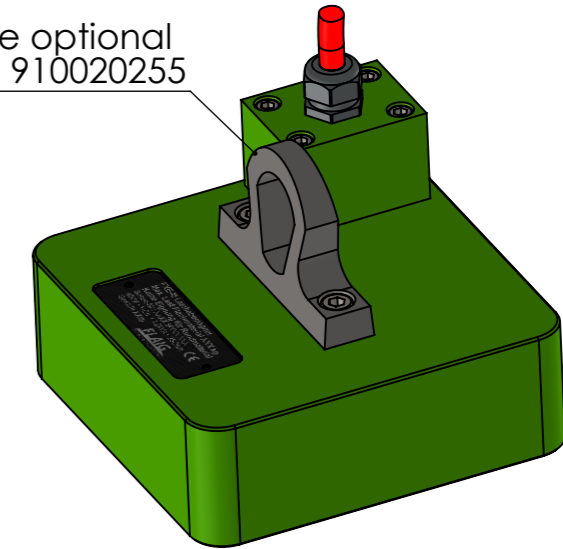

Specification FXE-M 300-50		Schutzvermerk nach DIN ISO 16016 beachten! Nachdruck nur mit unserer Genehmigung! All rights reserved according to DIN ISO 16016! Reprint with our permission only!				tolerance	material:	weight: 10.80
Nominative Force: 15,2kN	lifting capacity EN 13155/WLL			drawn	12.02.2021	MF	drawing no.:	<b>0012954</b>
Materialthickness >15mm (100%)	300kg			edit	29.04.2022		description:	<b>FXE M 300-50</b>
1,1kVA				appr.	11.04.2022	TW		
U: 380-480V Pulse	Protection Type IP 65			 www.flraig-te.de			part no.:	10610301
R: 24,8Ω	Protection category SK I	rev.	change			date	name	scale: 1:3
								sheet 1 / 1
								A3